

**Kołowrocki Krzysztof**

**Mazurek Jolanta**

**Soszyńska-Budny Joanna**

*Maritime University, Gdynia, Poland*

## Computer aided prediction of complex technical systems operation cost

### Keywords

complex technical system, operation process optimization, operation cost analysis, transportation system

### Abstract

There is presented the computer program is based on methods and algorithms for prediction of the operation cost of the complex technical system in variable operation conditions. The program allows to determine of the costs of the non-repairable and repairable complex technical systems before and after their operation processes optimization. The procedure of the computer program use and its application to operation cost analysis of the port oil transportation system are given.

### 1. Theoretical backgrounds

We consider the complex technical multi-state system consisted of  $n$  components and we assume that the operation costs of its single basic components in the operation state  $z_b$ ,  $b=1,2,\dots,\nu$ , during the system operation time  $\theta$ ,  $\theta \geq 0$ , amount

$$c_i(\theta, b), \quad i=1,2,\dots,n.$$

The following output characteristics of the complex technical system operation costs during the system operation time  $\theta$ ,  $\theta \geq 0$ , are determined after applying the computer program:

- the total cost of the non-repairable system

$$C(\theta) \cong \sum_{b=1}^{\nu} p_b \sum_{i=1}^n c_i(\theta, b),$$

where  $p_b$ ,  $b=1,2,\dots,\nu$ , are transient probabilities defined by (2.4) in [1];

- the total operation cost of the repairable system with ignored its renovation time

$$C_{ig}(\theta) \cong \sum_{b=1}^{\nu} p_b \sum_{i=1}^n c_i(\theta, b) + c_{ig} H(\theta, r),$$

where  $p_b$ ,  $b=1,2,\dots,\nu$ , are transient probabilities defined by (2.4) in [1] and  $H(\theta, r)$  is the mean value of the number of exceeding the critical reliability state  $r$  by the system during the operation time  $\theta$  that according to (4.4) from [1] is given by

$$H(\theta, r) = \frac{\theta}{\mu(r)}, \quad r \in \{1,2,\dots,z\},$$

where  $\mu(r)$  is the mean value of the unconditional system lifetime in the reliability state subset  $\{u, u+1, \dots, z\}$ , given by (3.6)-(3.7) in [1] for  $u=r$ ;

- the total operation cost of the repairable system with non-ignored its renovation time

$$C_{nig}(\theta) \cong \sum_{b=1}^{\nu} p_b \sum_{i=1}^n c_i(\theta, b) + c_{nig} \bar{\bar{H}}(\theta, r),$$

where  $p_b$ ,  $b=1,2,\dots,\nu$ , are transient probabilities defined by (2.4) in [1] and  $\bar{\bar{H}}(\theta, r)$  is the mean value of the number of renovations of the system during the operation time  $\theta$  that according to (4.12) from [1] is given by

$$\bar{\bar{H}}(\theta, r) \cong \frac{\theta}{\mu(r) + \mu_o(r)}, \quad r \in \{1, 2, \dots, z\},$$

where and  $\mu(r)$  is the mean value of the unconditional system lifetime in the reliability state subset  $\{u, u+1, \dots, z\}$ , given by (3.6)-(3.7) in [1] for  $u = r$ ;

- the total optimal cost of the non-repairable system after its operation process optimization

$$\dot{C}(\theta) = \sum_{b=1}^{\nu} \dot{p}_b \sum_{i=1}^n c_i(\theta, b),$$

where  $\dot{p}_b$ ,  $b = 1, 2, \dots, \nu$ , are optimal transient probabilities defined by (5.16) in [1];

- the optimal total operation cost of the repairable system with ignored its renovation time after its operation process optimization

$$\dot{C}_{ig}(\theta) \cong \sum_{b=1}^{\nu} \dot{p}_b \sum_{i=1}^n c_i(\theta, b) + c_{ig} \dot{H}(\theta, r),$$

where  $\dot{p}_b$ ,  $b = 1, 2, \dots, \nu$ , are optimal transient probabilities defined by (5.16) in [1] and  $\dot{H}(\theta, r)$  is the mean value of the optimal number of exceeding the critical reliability state  $r$  by the system during the operation time  $\theta$  that according to (5.28) from [1] is given by

$$\dot{H}(\theta, r) = \frac{\theta}{\dot{\mu}(r)}, \quad r \in \{1, 2, \dots, z\}.$$

where and  $\dot{\mu}(r)$  is the optimal mean value of the unconditional system lifetime in the reliability state subset  $\{u, u+1, \dots, z\}$ , given by (5.17)-(5.18) in [1] for  $u = r$ ;

- the total optimal operation cost of the repairable system with non-ignored its renovation time after its operation process optimization amounts

$$\dot{C}_{nig}(\theta) \cong \sum_{b=1}^{\nu} \dot{p}_b \sum_{i=1}^n c_i(\theta, b) + c_{nig} \dot{\bar{\bar{H}}}(\theta, r),$$

where  $\dot{p}_b$ ,  $b = 1, 2, \dots, \nu$ , are optimal transient probabilities defined by (5.16) in [1] and  $\dot{\bar{\bar{H}}}(\theta, r)$  is the mean value of the optimal number of renovations of the system that according to (5.36) from [1] is given by

$$\dot{\bar{\bar{H}}}(\theta, r) \cong \frac{\theta}{\dot{\mu}(r) + \mu_o(r)}, \quad r \in \{1, 2, \dots, z\},$$

where and  $\dot{\mu}(r)$  is the optimal mean value of the unconditional system lifetime in the reliability state subset  $\{u, u+1, \dots, z\}$ , given by (5.17)-(5.18) in [1] for  $u = r$ .

The output results of the computer application defined by these formulas allow us to compare the costs of the non-repairable and repairable complex technical systems with ignored and non-ignored times of renovations before and respectively after the optimization of their operation processes.

## 2. Description of the computer program capabilities

To make the estimation and to compare the operation costs of the non-repairable and repairable complex technical system with ignored and non-ignored times of renovations in variable operation conditions before and after the optimization of its operation process its operation should be fixed following input parameters (*Figure 1*).

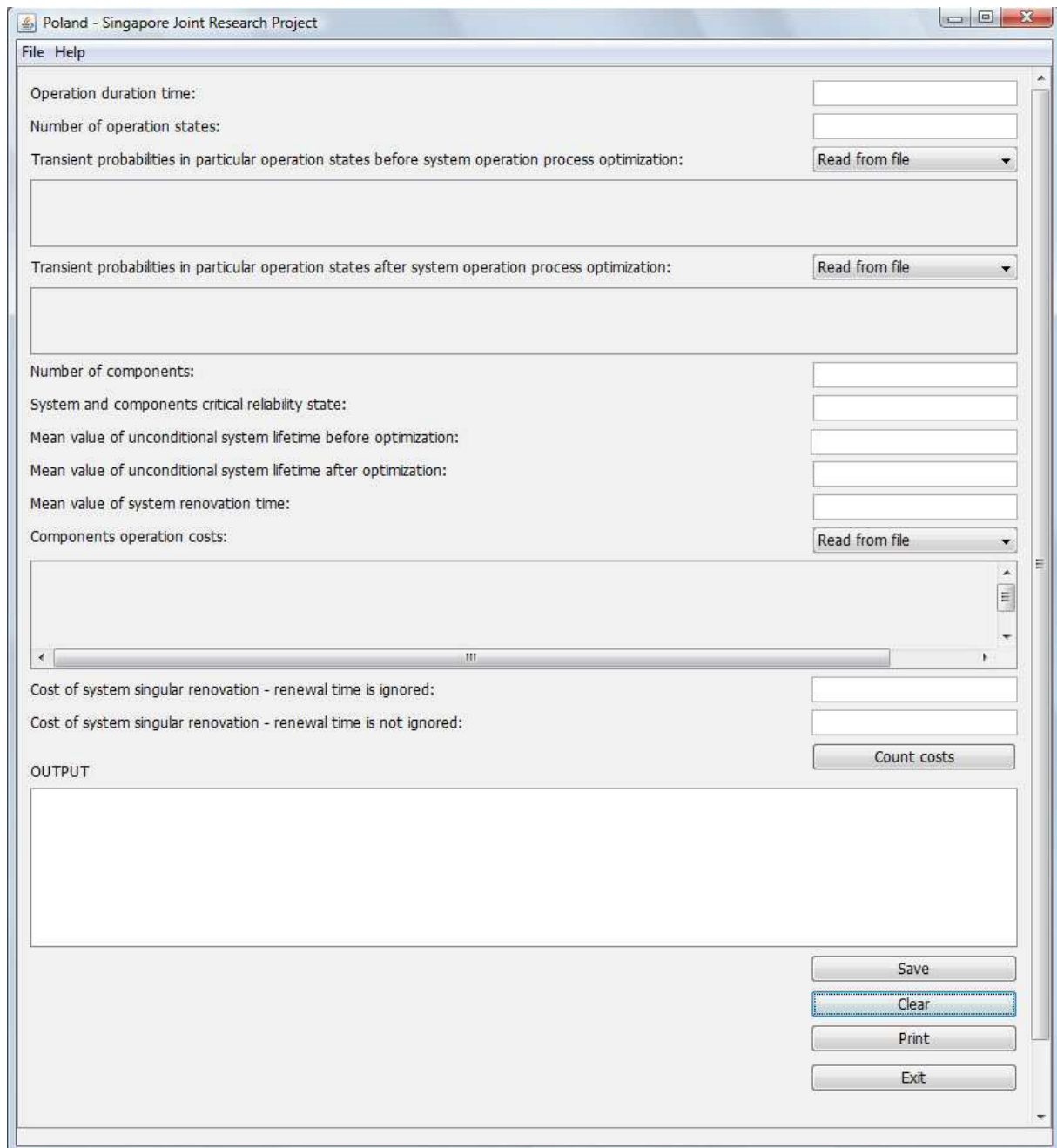

Figure 1. The program window

The input parameters of the system operation process (Figure 2):

- the time of the system operation process duration  $\theta$ ,
- the number of the operation states of the system operation process  $\nu$ ,
- the operation states of the system operation process  $z_1, z_2, \dots, z_\nu$ ,
- the transient probabilities in particular operation states before the system operation process optimization  $p_1, p_2, \dots, p_\nu$ ,
- the transient probabilities in particular operation states after the system operation process optimization  $\dot{p}_1, \dot{p}_2, \dots, \dot{p}_\nu$ .

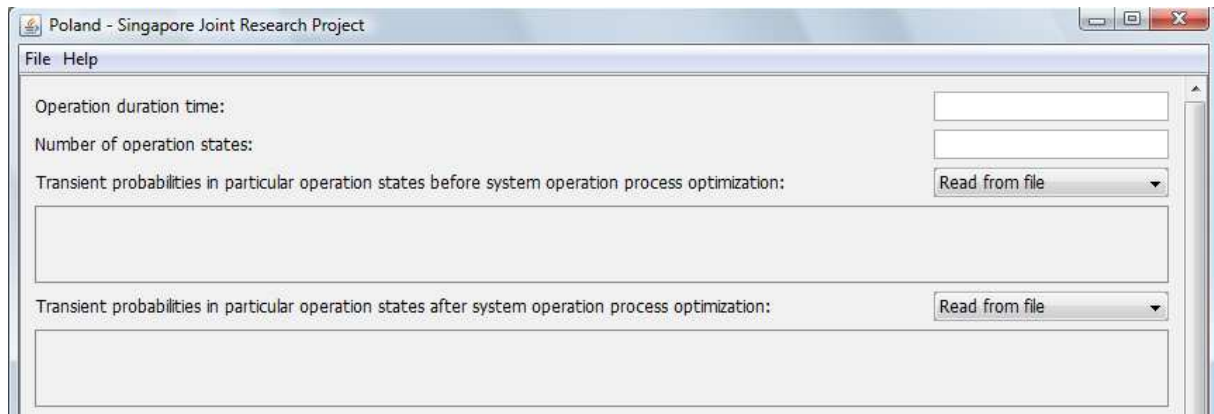

Figure 2. The program window – the input parameters

The input parameters of the complex technical system reliability and renewal models (Figure 3):

- the total number of the system components  $n$ ,
- the system and components critical reliability state  $r$ ,
- the mean value of the unconditional lifetime of the system in the reliability states subset not worse than the system critical reliability state  $r$  before its operation process optimization  $\mu(r)$ ,

- the mean value of the unconditional lifetime of the system in the reliability states subset not worse than the system critical reliability state  $r$  after its operation process optimization  $\dot{\mu}(r)$ ,
- the mean value of the system renovation time  $\mu_0(r)$  - only in the case of a repairable system with non-ignored renovation time.

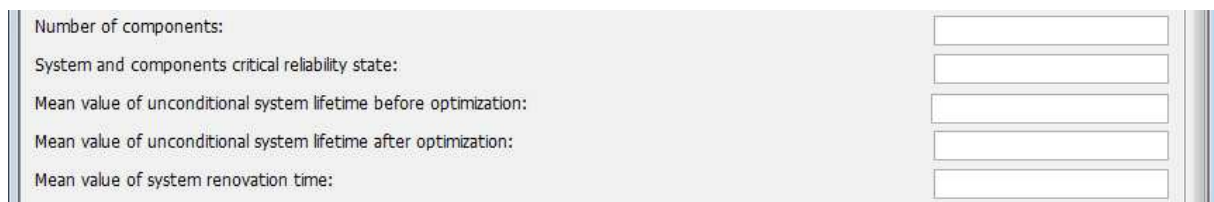

Figure 3. The program window – the input parameters

The input parameters for the complex technical system operation cost model (Figure 4):

- the matrix of the operation costs  $c_i(\theta, b)$ ,  $i = 1, 2, \dots, n$ ,  $b = 1, 2, \dots, v$ , of the system single basic components  $E_i$ ,  $i = 1, 2, \dots, n$ , at the operation state  $z_b$ ,  $b = 1, 2, \dots, v$ , during the system operation time  $\theta$ ,

- the cost of the singular renovation of the repairable system with ignored time of renovation  $c_{ig}$ ,
- the cost of the singular renovation of the repairable system with non-ignored time of renovation  $c_{nig}$ .

$$[c_i(\theta, b)]_{n \times v} = \begin{bmatrix} c_1(\theta, 1) c_1(\theta, 2) \dots c_1(\theta, v) \\ c_2(\theta, 1) c_2(\theta, 2) \dots c_2(\theta, v) \\ \dots \\ c_n(\theta, 1) c_n(\theta, 2) \dots c_n(\theta, v) \end{bmatrix},$$

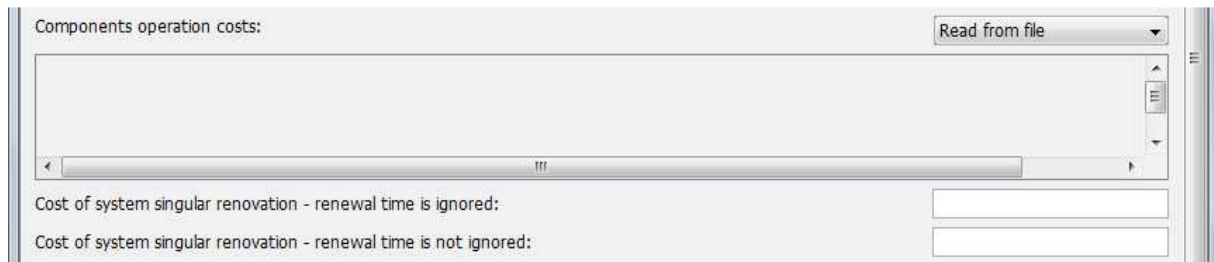

Figure 4. The program window – the input parameters

After pressing the button “Count costs”, the computer program is estimating operation costs of

the complex technical systems. The results are shown on the screen in the widow „OUTPUT” (Figure 5).



Figure 5. The program window – the output parameters

### 3. Prediction of the operation cost of real complex technical systems - the port oil piping transportation system

The considered port oil piping transportation system is the main part of the Oil Terminal in Dębogórze

that is designated for the reception from ships, the storage and sending either by carriages or by cars the oil products such like petrol and oil. The scheme of this terminal is presented in Figure 6.

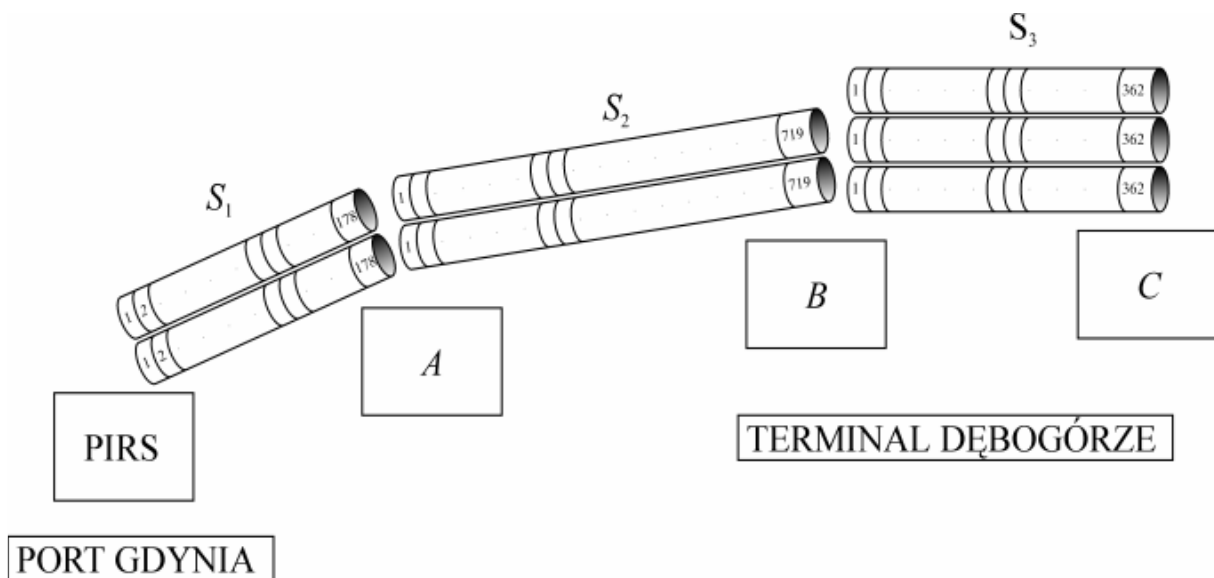

Figure 6. The scheme of the port oil piping transportation system

The oil pipeline transportation system consists of three subsystems  $S_1, S_2, S_3$ :

- the subsystem  $S_1$  is composed of two identical pipelines, each composed of 176 pipe segments of length 12m and 2 valves, denoted respectively by  $E_{ij}^{(1)}, i=1,2, j=1,2,\dots,178$ ,
- the subsystem  $S_2$  is composed of two identical pipelines, each composed of 717 pipe segments of length 12m and 2 valves, denoted respectively by  $E_{ij}^{(2)}, i=1,2, j=1,2,\dots,719$ ,
- the subsystem  $S_3$  is composed of two identical and one different pipelines, each composed of 360 pipe segments of either 10 m or 7,5 m length and 2 valves, denoted respectively by  $E_{ij}^{(3)}, i=1,2,3, j=1,2,\dots,362$ .

The input parameters of the port oil piping transportation system operation process (Figure 7):

- the time of the system operation process duration  $\theta=1$  year,
- the number of the pipeline system operation process states  $\nu=7$ ,
- the following as its seven operation states:
  - an operation state  $z_1$  – transport of one kind of medium from the terminal part B to part C using two out of three pipelines in subsystem  $S_3$ ,
  - an operation state  $z_2$  – transport of one kind of medium from the terminal part C (from carriages) to part B using one out of three pipelines in subsystem  $S_3$ ,
  - an operation state  $z_3$  – transport of one kind of medium from the terminal part B through part A to pier using one out of two pipelines in subsystem  $S_2$  and one out of two pipelines in subsystem  $S_1$ ,
  - an operation state  $z_4$  – transport of two kinds of medium from the pier through parts A and B to part C using one out of two pipelines in subsystem  $S_1$ , one out of two pipelines in subsystem  $S_2$  and two out of three pipelines in subsystem  $S_3$ ,
  - an operation state  $z_5$  – transport of one kind of medium from the pier through part A to B using one out of two pipelines in subsystem  $S_1$  and one out of two pipelines in subsystem  $S_2$ ,

- an operation state  $z_6$  – transport of one kind of medium from the terminal part B to C using two out of three pipelines in subsystem  $S_3$ , and simultaneously transport one kind of medium from the pier through part A to B using one out of two pipelines in parts  $S_1$  and one out of two pipelines in subsystem  $S_2$ ,
- an operation state  $z_7$  – transport of one kind of medium from the terminal part B to C using one out of three pipelines in part  $S_3$ , and simultaneously transport second kind of medium from the terminal part C to B using one out of three pipelines in part  $S_3$ ,
- the transient probabilities  $p_b$  in particular operation states  $z_b, b=1,2,\dots,7$ , before the system operation process optimization  $p_1=0.389, p_2=0.062, p_3=0.003, p_4=0.002, p_5=0.2, p_6=0.058, p_7=0.286$ ,
- the transient probabilities  $\dot{p}_b$  in particular operation states  $z_b, b=1,2,\dots,7$ , after the system operation process optimization

$$\dot{p}_1=0.210, \dot{p}_2=0.609, \dot{p}_3=0.02, \dot{p}_4=0.06,$$

$$\dot{p}_5=0.05, \dot{p}_6=0.001, \dot{p}_7=0.05.$$

Figure 7. The input parameters of the port oil piping transportation system

The input parameters of the port oil piping transportation system reliability and renewal models (Figure 8):

- the total number of the system components  $n = 2880$ ,
- the number of the system and components reliability states is 3 ( $z = 2$ ),
- the system and components reliability states, after discussion with experts, are:
  - a reliability state 2 – piping operation is fully safe,
  - a reliability state 1 – piping operation is less safe and more dangerous because of the possibility of environment pollution,
  - a reliability state 0 – piping is destroyed and it is assumed that are possible the transitions between the components reliability states only from better to worse ones,
- the system and components critical reliability state is  $r = 1$ ,
- the mean value of the unconditional lifetime of the system in the reliability states subset not worse than the system critical reliability state 1 before its operation process optimization  $\mu(1) = 0.363$ ,
- the mean value of the unconditional lifetime of the system in the reliability states subset not worse than the system critical reliability state 1 after its operation process optimization  $\hat{\mu}(1) = 0.61$ ,
- the mean value of the system renovation time  $\mu_0(1) = 0.005$  - in the case of a repairable system with non-ignored renovation time

Figure 8. The input parameters of the port oil piping transportation system

The input parameters of the port oil piping transportation system cost model (Figure 9).

- the operation costs  $c_i(\theta, b) = 9.6$  PLN,  $b = 1, 2, \dots, 7$ ,  $i = 1, 2, \dots, 2880$  of the system single basic components during the system operation time  $\theta$  Whereas, the cost of each system singular basic component that is not used is equal to 0,
- in the case when the pipeline transportation system is repaired after exceeding the critical reliability state  $r = 1$  and its renewal time is ignored, according to the expert opinion, we assume that the approximate cost of the system singular renovation is  $c_{ig} = 88500$  PLN,
- in the case when the pipeline transportation system is repaired after exceeding the critical reliability state  $r = 1$  and its renewal time is not ignored, according to the expert opinion, we assume that the approximate cost of the system singular renovation is  $c_{nig} = 90000$  PLN.

Components operation costs:							Enter data from keyboard
0	0	9.6	9.6	9.6	9.6	0	
0	0	9.6	9.6	9.6	9.6	0	
0	0	9.6	9.6	9.6	9.6	0	
Cost of system singular renovation - renewal time is ignored:							88500
Cost of system singular renovation - renewal time is not ignored:							90000

Figure 9. The input parameters of the port oil piping transportation system

After pressing the button “Count costs”, the computer program is estimating operation costs (Figure 10).

```
OUTPUT
Total cost of non-repairable system: 12838.694400000171
Total cost of repairable system - renewal time is ignored: 256640.3472925622
Total cost of repairable system - renewal time is not ignored: 257403.91179130453
Total cost of non-repairable system after optimization: 11951.942399993142
Total cost of repairable system after optimization - renewal time is ignored: 157033.90961310788
Total cost of repairable system after optimization - renewal time is not ignored: 158293.40581462727
```

Figure 10. The output parameters of the port oil piping transportation system

#### 4. Conclusion

The computer program for the prediction of the complex technical systems operation costs is based on the methods and algorithms from [1]. The computer program is the supplement to the training course directed to industry included in [2] where it is used for predicting the characteristics of the operation costs of real technical port, shipyard and maritime transportation systems. It can also be used as the supporting tool in the Integrated Safety and Reliability Support System - IS&RSS [3] for various maritime and coastal transport transportation systems operation costs analysis.

#### Acknowledgements

The paper presents partial results of the work in the Poland-Singapore Joint Research Project titled “Safety and Reliability of Complex Industrial Systems and Processes” supported by grants from the Poland’s Ministry of Science and Higher Education (MSHE grant No. 63/N-Singapore/2007/0) and the Agency for Science, Technology and Research of Singapore (A\*STAR SERC grant No. 072 1340050).

#### References

- [1] Blokus-Roszkowska, A., Kołowrocki, K. & Soszyńska, J. (2009). Methods of complex technical systems operation, reliability, availability, safety and cost optimization. Task 7.5 in WP7: Integrated Package of Solutions for Complex industrial Systems and Processes Safety

and Reliability Optimization. Report. Poland-Singapore Joint Research Project. MSHE Decision No. 63/N-Singapore/2007/0. Gdynia Maritime University.

- [2] Blokus-Roszkowska, A., Guze, S., Kołowrocki, K. & Soszyńska, J. (2010). Operation cost analysis of complex technical systems - Training course addressed to industry, Task 11.12 in WP 11: Education, Training, Results Dissemination and Implementation. Report. Poland-Singapore Joint Research Project. MSHE Decision No. 63/N - Singapore/2007/0. Gdynia Maritime University.
- [3] Kołowrocki, K. & Soszyńska, J. (2010). Integrated Safety and Reliability Support System – IS&RSS, Tasks 10.0-10.16 in WP 10: Education, Training, Results Dissemination and Implementation. Report. Poland-Singapore Joint Research Project. MSHE Decision No. 63/N-Singapore/2007/0. Gdynia Maritime University.